

# Deadbolt Installation/Single Cylinder and Double Cylinder

## Exploded View Single Cylinder Deadbolt

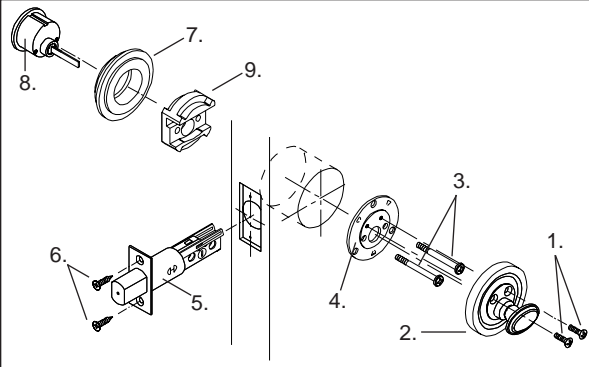

### Parts Enclosed:

- |   |   |
|---|---|
| 1. 2 each #8 - 32 Oval Head Machine Screw         | 5. 1 Adjustable Backset Deadbolt                |
| 2. 1 Turnpiece Trim                               | 6. 4 each #8 x 3/4" Flathead Combination Screws |
| 3. 2 each #10 - 32x 1-7/8" Pan Head Machine Screw | 7. 1 Outside Cylinder Collar                    |
| 4. 1 Turnpiece Mounting Plate                     | 8. 1 Outside Cylinder                           |
|   | 9. Screw Guide                                  |

Note: See Strike Installation section for strike parts listing.

## Exploded View Double Cylinder Deadbolt

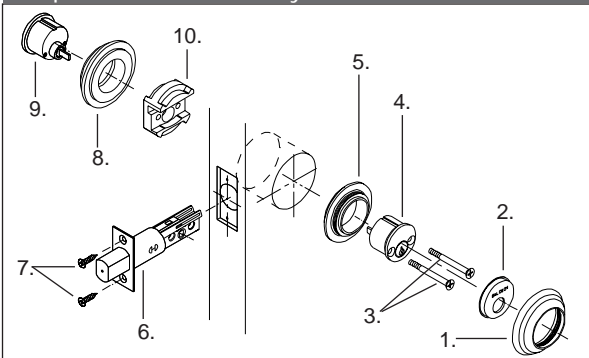

### Parts Enclosed:

- |  |   |
|--|---|
| 1. 1 Inside Cylinder Collar                        | 6. 1 Adjustable Backset Deadbolt                |
| 2. 1 Cylinder Cover                                | 7. 4 each #8 x 3/4" Flathead Combination Screws |
| 3. 2 each #10 - 32x2-1/4" Flat Head Machine Screws | 8. 1 Outside Cylinder Collar                    |
| 4. 1 Inside Cylinder                               | 9. 1 Outside Cylinder                           |
| 5. 1 Threaded Collar                               | 10. Screw Guide                                 |

Note: See Strike Installation section for strike parts listing.

### Tools Needed: Only Required for Doors Without Cutout

If your door is not pre-bored, see reverse side of instructions for door preparation.

- |                             |  |
|-----------------------------|--|
| 1. Pencil                   | 3. 1/2" or 3/4" wood chisel                    |
| 2. 2-1/8" diameter hole saw | 4. Drill and assorted bits: 1/8", 5/32" and 1" |

### Tools Needed: Doors Prepared with 2-1/8" Cutout

- |  |                                   |
|--|-----------------------------------|
| 1. No. 2 and No. 3 phillips screwdrivers | 3. Two pliers for Double Cylinder |
| 2. Measuring device                      | 4. Flathead Screwdriver           |

### Optional Deadbolt Accessories for 1-3/8" Doors

When installing deadbolts on 1-3/8" thick doors, optional Cylinder Collar Spacers are required (No. 8297). Consult your Baldwin distributor for further details.

## Door Preparation

- To position template fold enclosed template on line and locate on door at specified height (about 40" from the floor). If you have a new door that is not already cut-out, please follow these instructions. If your door is pre-bored please proceed to Single Cylinder & Double Cylinder Deadbolt Installation-Step 1. If the door is beveled, place the folded edge on low side of bevel as shown in the illustration. Determine door thickness and backset (2-3/8" or 2-3/4"). Mark the door for face and edge bores.

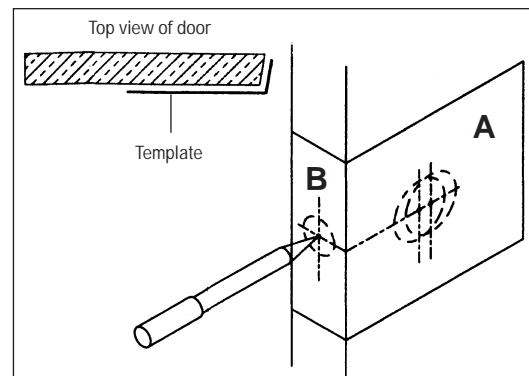

- Drill the 2-1/8" diameter face bore (A) through the door and 1" diameter edge bore (B) 3-1/2" deep for a 2-3/8" backset or 3-7/8" deep for a 2-3/4" backset. The bolt accommodates both size backsets. Caution: Re-check hole locations before drilling.

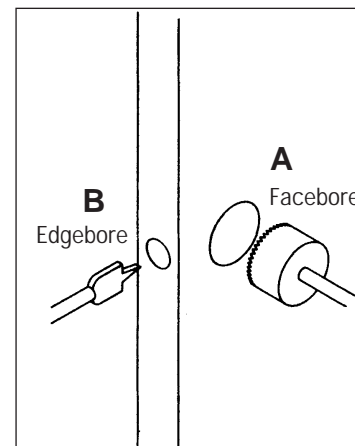

- Insert deadbolt into edge of door while holding faceplate. Trace the outline of the faceplate onto the door edge. Mark screw hole centers and drill with a 1/8" drill.

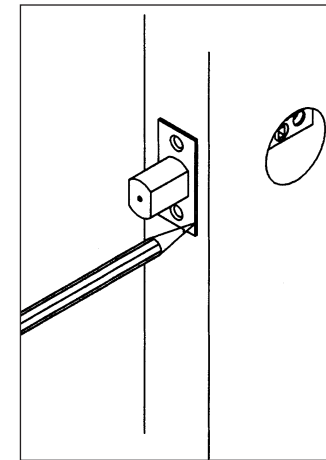

- Chisel out the area marked for the faceplate to a depth of 5/32" or until faceplate is flush with door edge. Proceed now to the [Strike Installation](#)

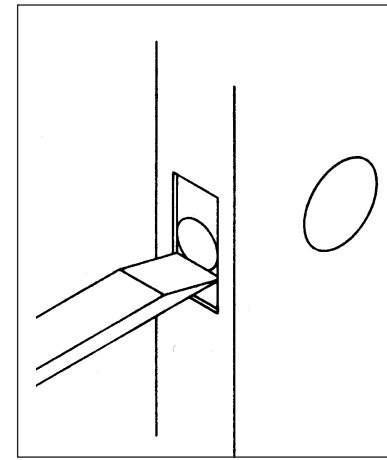

## Strike Installation

- Close door and extend deadbolt several times against door frame. Strike centering indicator will leave a center mark on the door frame. (fig. 1)

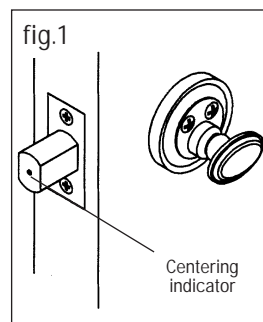

- Position strike plate on center mark. Align and trace outside of strike and mounting screws onto the door frame. (fig. 2)

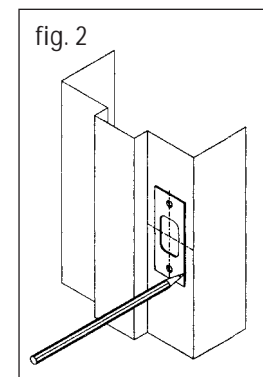

- Using reinforcing strike as a template, mark locations for reinforcing screws. (fig. 3) Drill two 5/32" dia. pilot holes for the 3" long screws and two 1/8" dia. pilot holes for the #8 x 3/4" screws. Mark drill points 5/16" above and below centering point. Bore two 1" dia. holes 1-1/4" deep at these points. Chisel out holes for dust box. (fig. 4)

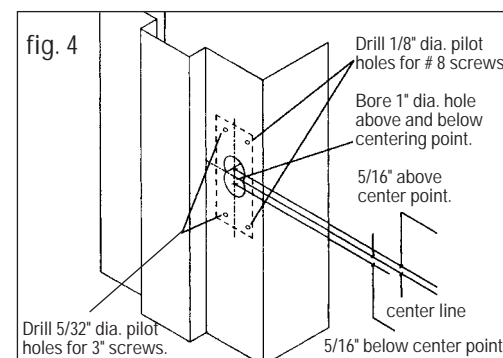
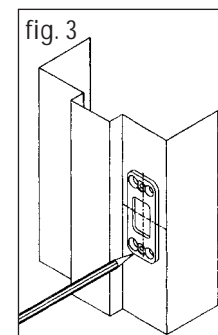

- Mortise 7/32" deep or until the strike box, reinforcing strike and strike plate fits inside mortise and flush with the door frame. (fig. 5)

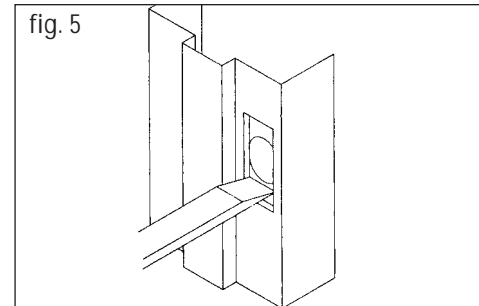

- Install strike as illustrated.

- Dust Box
- Reinforcing Strike
- #8 x 3/4" Combination Screws (2)
- 3" Reinforcing Screws\* (2)
- Strike Plate
- #8-32 x 1/4" Machine Screws (2)

\*Note: Lubricant recommended when installing 3" reinforcing screws.

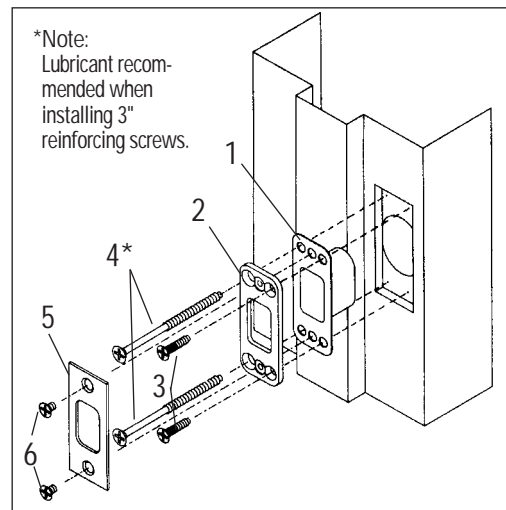

TEAR HERE FOR ENGLISH.

TEAR HERE FOR ENGLISH.

## 2-1/8" Deadbolt Preparation

### Congratulations!

With your purchase of The Images Collection solid brass deadbolt, you're among a group of discerning individuals who know the intrinsic value of selecting the finest – Baldwin.

Images entrance locksets, interior latchsets, and deadbolts coordinate beautifully, enabling you to carry a specific design theme throughout your home.

Our step-by-step installation instructions will help guide you through your project quickly and easily.

Before you begin your installation, read and understand the installation instructions and marking templates. If you have any questions, please do not hesitate to contact our Baldwin Technical Services Department, 1-800-566-1986. We're here to help!

NOTE: Failure to use all recommended components will void Grade 1 rating.

We thank you for your Baldwin purchase and wish you the fullest enjoyment of your Baldwin Handleset.

Technical Services Support  
1-800-566-1986

Hours: 6 am to Midnight C.S.T.-7days a week.

©Baldwin Hardware Corporation  
P.O. Box 15048 Reading, PA 19612

PK-1152-T (8/00)

### Remember Baldwin



With the completion of your project, remember that Baldwin quality hardware and giftware products are available for all your decorating and remodeling needs. Matching knob and leversets for interior doors, beautiful bath accessories, and a complete selection of cabinet and door enhancing hardware are all available from your Baldwin retailer.



### Single Cylinder Assembly

- 1 a. Extend deadbolt using flathead screwdriver. Keeping tailpiece vertical, insert cylinder through collar and screw guide into deadbolt. The arrow on the screw guide must be on the outside and pointing up. Hold in place. Do not insert key during this procedure. (fig. 1)

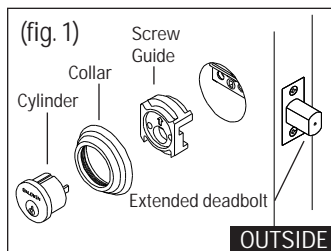

- b. Place turnpiece mounting plate on inside of door as shown. The side with "TOP" marked on plate should be against the door. Attach cylinder using two #10-32 x 1-7/8" pan head machine screws. Insert screws through mounting plate, deadbolt, screw guide and collar into the cylinder. Tighten all screws. (fig. 2)

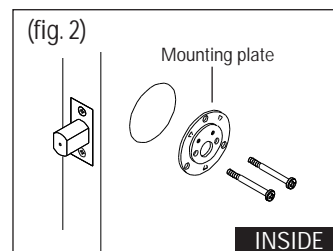

- c. Place turnpiece trim over mounting plate. Insert tailpiece into turn piece. Attach trim to mounting plate with two #8-32 x 5/8" oval head machine screws. Tighten screws. (fig 3)

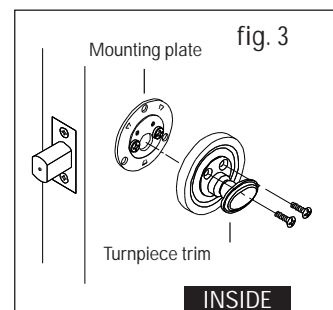

### Installing Deadbolt

- 1 a. The deadbolt supplied with this unit has an adjustable backset feature. It will be set at 2-3/8" backset. To adjust to 2-3/4" backset, grasp body and twist face-plate/bolthead assembly 180° until it stops. Unit is now ready for installation in a 2-3/4" backset configuration.

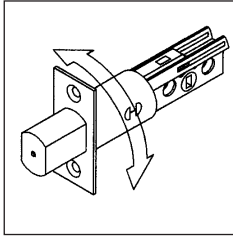

- b. Insert deadbolt. Install with two #8 x 3/4" flat head combination screws provided (see diagram for proper positioning). Ensure deadbolt head is extended throughout installation procedure.

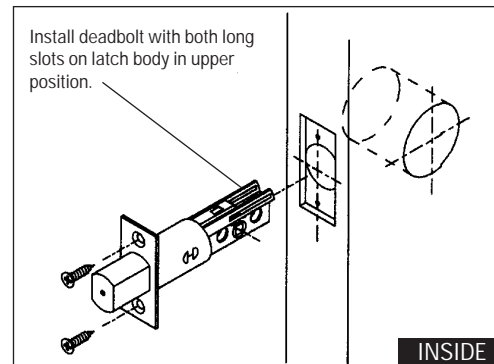

### Double Cylinder Assembly

- 1 a. Carefully break off cylinder tailpiece at required mark for your door thickness. Caution; use two pairs of pliers as shown or tail-piece will be damaged.
- b. Align tailpiece with slot. Keep tailpiece vertical and curved toward right side of the hole as illustrated.

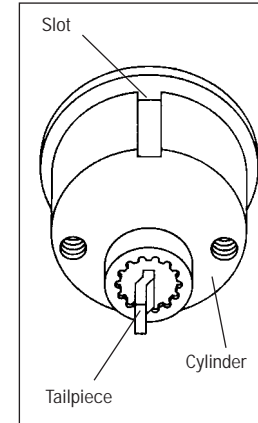
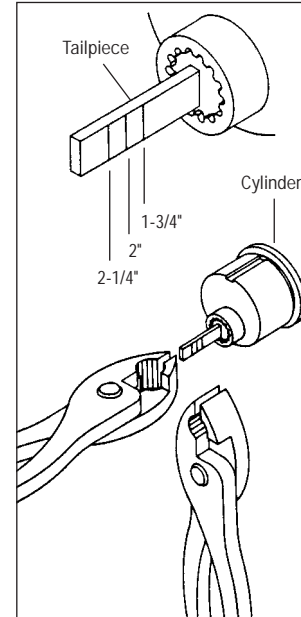

- 2 a. Extend deadbolt using flathead screwdriver. Keeping tailpiece vertical and toward the right side of hole, insert outside cylinder through collar, screw guide, then into the deadbolt. Align slot of inside cylinder with notch in threaded collar. Keeping tailpiece vertical and curved toward the right side of hole, insert inside cylinder with threaded collar into the deadbolt. Attach cylinders using two #10-32 x 2-1/4" flat head machine screws. Tighten screws. Do not insert key during this procedure. (fig.4)

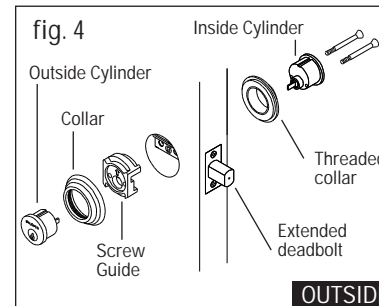

- b. Align cylinder cover over inside cylinder. Screw on decorative cylinder collar. Congratulations! Your installation is now complete!

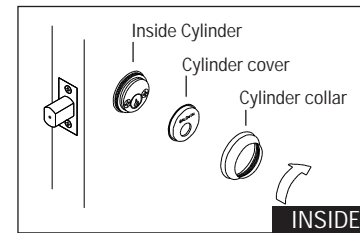

# BALDWIN

## 2-1/8" Collar Auxiliary Deadbolt Installation Instructions



PK-1152-T (8/00)

TEAR HERE FOR ENGLISH.

TEAR HERE FOR ENGLISH.